

## Smart Homes and Smart Cities: Applications in Internet of Things (IoT)

Thallyson Paulino\*, L.F. Avila

### Abstract

Living in smart cities or smart homes, or having applications turned to them, has become a reality for many people, and when we put this applications into the world of Internet Of Things (IoT), we start talking about a better performance of results. This research develops an application for smart homes: a smart power strip.

### Key words:

Internet of Things; Microcontrollers; Smart Homes.

### Introduction

Internet of Things is the communication among objects by using Internet [1]. In the context of Internet of Things we have wireless sensor networks, actuators and RFID (Radio Frequency Identification) technologies. These devices are heterogeneous and allow, through a physical medium, to acquire data for processing, providing services of users interest. For smart homes, its automation is a technology that can provide security, energy efficiency and comfort, as well as an increase in the quality of life [2]. In the case of smart cities, we have problems of displacement, traffic, security, street lighting and commercial facilities. In this case, the automation are being used through applications that can meet citizens needs efficiently and with good results. The development of applications for smart homes or smart cities can be done from several technologies. Since the involvement with microcontrollers, mobile applications and computer systems is necessary. In this project it was used the Intel Galileo Microcontroller, based on the Intel x86 architecture and having some vantanges over the conventional Arduino, such as an integrated Ethernet port and an SD card reader [3].

### Results and Discussion

The Image 1 shows the diagram used for the basic creation for the application:

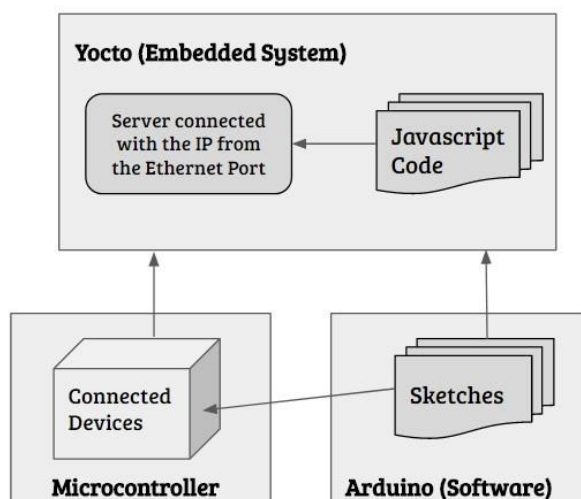

Figure 1. Diagram for applications development.

The devices connected to the microcontroller were a power strip and an eight-output relay module, with only four of them being used. With the Arduino software, the necessary codes are executed for the application and with the embedded system Yocto, present in the micro SD insert in the microcontroller, it is possible to connect the application to the internet through the IP of the Ethernet port. A Javascript code defines the commands required to control the application, and thus, through an FTP connection, this file is transferred remotely to the embedded system and finally, the application is executed through a web browser, using the following syntax: IP /Command.

This command for the power strip case is related to the activation or deactivation of the electronic devices that can be connected. The overall operation of the application can be understood as the automatic control over the internet of the devices in the room of a house through a power strip. The power strip allows the connection of four devices, when devices are connected, it will not work instantly, because it will be conditioned to the relay that is controlled by the command coming from the web navigation through any browser. Thus, through any device with an internet connection, and access to the server, it is possible to connect or disconnect these devices from anywhere in the world.

### Conclusions

Through a theoretical approach on smart homes and smart cities, it was possible to understand the concepts and apply in practice a methodology to develop an application that uses concepts of embedded systems, microcontrollers and the internet of things, simulating an smart power strip.

### Acknowledgement

The authors thank to the Programa Institucional de Bolsas de Iniciação em Desenvolvimento Tecnológico e Inovação - PIBITI/CNPq for the financial support.

<sup>1</sup> Charith P., Arkady Z., Peter C. and Dimitrios G.: Context Aware Computing for The Internet of Things: A Survey. IEEE Communications Surveys & Tutorials (2014).

<sup>2</sup> Weihua S., Yoky M., Yongsheng Ou, Meiqin Liu, Fulvio M.: Special Section on Home Automation. IEEE Transactions on Automation Science And Engineering (2015).

<sup>3</sup> Boban D., Aleksandra L.: A Smart Home System Based on Sensor Technology. Facta Universitatis, Series: Electronics and Energetics (2016).