

X-ray quarter wave plate for magnetic dichroism

Eduardo H. T. Poldi*, Carlos A. Escanhoela Jr., Jairo Fonseca Jr., Narcizo M. Souza Neto.

Abstract

This project fits well in the strategy to develop experimental stations in the current synchrotron light source that can be moved, without modifications, to the new synchrotron light source under construction. The main goal of this project is to use a X-ray 1/4 wave plate, unique in the world, to convert linearly polarized X-rays into circularly polarized for efficient X-ray magnetic circular dichroism experiments. The complete experimental set-up to use the X-ray 1/4 wave plate was designed and it's already been commissioned, so XMCD experiments at magnetic fields of up to 6 T will be feasible with dispersive optics in the next few months.

Key words:

Scientific instrumentation, magnetism, X-ray spectroscopy.

Introduction

The main goal of this project is to use a X-ray 1/4 wave plate^{1, 2, 3} to convert linearly polarized X-rays into circularly polarized for efficient X-ray magnetic circular dichroism experiments. This plate is made of birefringent material, single crystalline diamond in this case, so its refraction index depends on the incidence angle and generates a phase retardation of 90° between the horizontal and vertical components of the electrical field. This instrumentation is motivated by the need to have the total control of the polarization and a fast helicity switching, besides the improvement of the polarization rate and beam intensity, today limited to 70% circularly polarized and ~1/3 of the initial intensity.

Results and Discussion

We have designed a complete experimental set-up to use the 1/4 wave plate at two beamlines of LNLS, and one beamline of the future synchrotron Sirius.

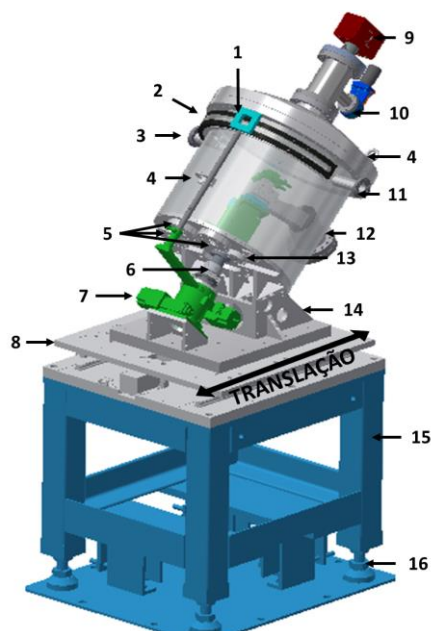

Image 1. Schematics of the quarter wave plate support, with the vacuum chamber outside. The incidence angle of the X-ray beam on the phase retarder is controlled by the

θ motor and the diffracted X-ray angle is 2θ , where the photodiode is localized. 1) Photodiode; 2) Be window for the diffracted beam measurement; 3) Be window (beam out); 4) Eye bolts; 5) Electrical Feedthroughs; 6) Mechanical Feedthrough; 7) θ - 2θ motors; 8) Motorized translation table; 9) Ion pump; 10) Valve to connect a turbo pump; 11) Be window (beam in); 12) Viewport; 13) Vacuum gauge connection; 14) Vacuum chamber support; 15) Bed; 16) Base with adjustable height.

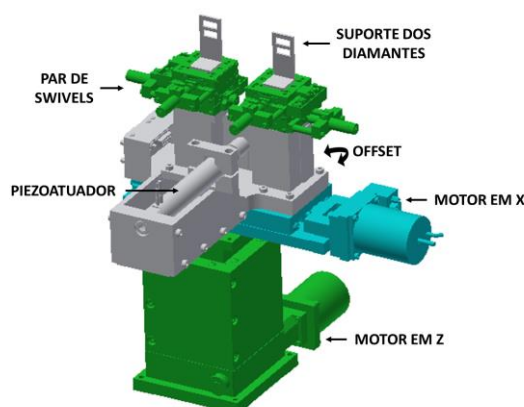

Image 2. Representation of the ensemble of motors and the quarter wave plate support that will be utilized inside the vacuum chamber.

Conclusions

With preliminary experiments, we have successfully generated 98% rate of circularly polarized X-rays with a diamond quarter wave plate at the goniometry currently available at the XDS beamline. We are currently commissioning the final set-up to allow efficient XMCD experiments at magnetic fields of up to 6 T in the next few months.

Acknowledgement

We'd like to thank FAPESP for the support to this project.

¹ Hirano, K. et al. *Japanese J. of Applied Physics*, **1991**, L407-L410.

² Giles, C. et al. *J. of Applied Crystallography*, **1994**, 232-240.

³ Lang, J. C.; Srajer, G. *Review of Scientific Instruments*, **1995**, 1540-1542.